

PART NUMBER	REV	A	B	C	D	ØE	ØF	DETAIL		COMMENT
								H	DIM	

REVISIONS			
REV	DESCRIPTION	DATE	APPROVAL
N/C	RELEASED		

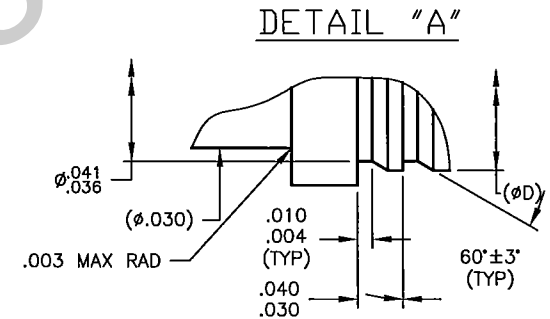

8. CONTACT MEETS OR EXCEEDS SPECIFICATION AND REQUIREMENTS OF MIL-C-39029/58-360. EXCEPT AS INDICATED HEREIN.
 7. IDENTIFICATION GROOVE
 - A. INCLUDED
 - B. NOT INCLUDED
 6. CONTACT SHALL MEET THE SOLDERABILITY REQUIREMENTS OF MIL-STD-202, METHOD 208
 5. ALL DIAMETERS ON A COMMON CENTERLINE ARE TO HAVE A CIRCULAR RUNDOUT OF .002 MAX.
 4. DIMENSIONS SHOWN ARE AFTER PLATING.
 3. FINISH: .000050 THICK MINIMUM GOLD PER MIL-G45204, TYPE II, GRADE C, CLASS 1
OVER .000050-.000100 THICK SULFAMATE NICKEL PER QQ-N-290, CLASS 2,
OVER .00015 THICK MINIMUM COPPER PER MIL-C-14550.
 2. MATERIAL: A. SUITABLE COPPER ALLOY (LEADED NICKEL COPPER).
B. BRASS PER ASTM B16 UNS C36000 H02
C. BeCu (WITH HEAT TREATMENT)
D. YOUR CHOICE
 1. INTERPRET DRAWING PER ASME-14.5M - 1994.
- NOTES: UNLESS OTHERWISE SPECIFIED.

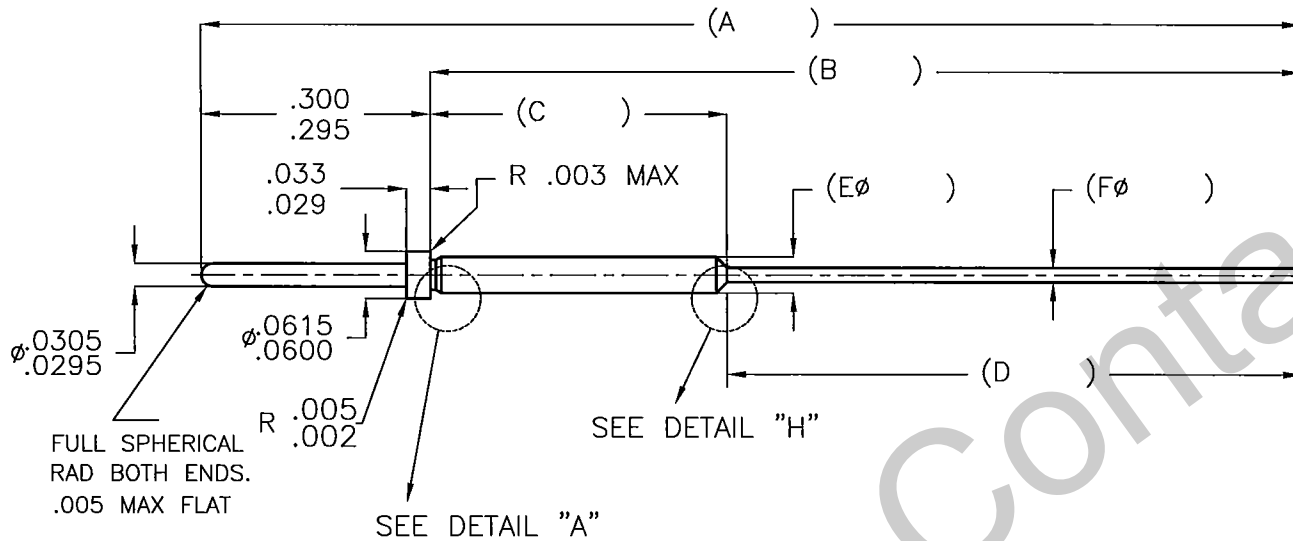
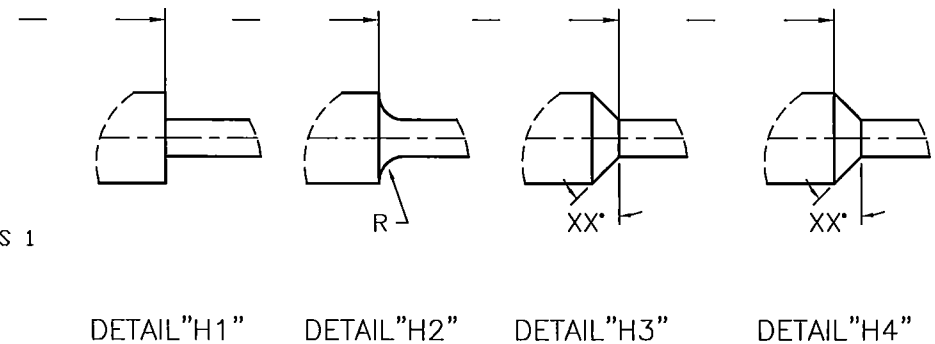

Aerospace
Contacts LLC

THIS DOCUMENT IS ISSUED IN STRICT CONFIDENCE ON THE CONDITION THAT IT IS NOT TO BE USED AS THE BASIS FOR MANUFACTURING OR SALE, AND THAT IT IS NOT TO BE COPIED, REPRINTED OR DISCLOSED TO A THIRD PARTY EITHER WHOLLY OR IN PART WITHOUT THE WRITTEN CONSENT OF AEROSPACE CONTACTS, LLC.

REFERENCE: MIL-C-39029/58-360

DRAWN	SzL	01.01.2009
CHECKED		
APPROVED		

DIMENSIONS ARE IN INCHES
TOLERANCES:
DECIMALS:
.XX = ±.005
.XXX = ±.003

ANGLES:
±1°

MATING CONTACT: MIL-C-39029/56 or 57

TYPE: CONTACT

CONTACT #22
PIN/PC

CAGE: 1 SHEET OF 1 PART NUMBER ACLLC